



MATERIAL HANDLING
EQUIPMENT

Can Palletizer/Depalletizer

The Whallon Machinery can palletizer/depalletizer automatically transfers cans from conveyor to pallet or from pallet to conveyor. In the palletize mode, the magnetic head lifts a pattern of cans off the accumulation table, rotates 90 degrees and places the layer on a receiving pallet. The unit continues to stack each successive pattern until the desired pallet height is reached. In the depalletize mode, single layers of cans are lifted off the pallet and placed onto the table which transfers the cans to the desired location. The semi-automatic operation of the machine allows the operator to manage multiple stations or complete additional tasks.

The Whallon can palletizer/depalletizer is a flexible unit that can be placed into almost

any layout. The different configuration of single filers, accumulation tables, and pallet conveyors enable the system to operate under space restrictions or with existing lines and equipment. The versatility of the machine is limited only by the customers' requirements. The palletizer/depalletizer can handle cans in size from 201 to 701 diameters. Assemblies can be purchased to handle speeds up to four layers per minute. The units can automatically control all pallet handling and slip sheet removal or work in a semi-automatic mode. Specialty units include 180 degree tube assemblies that can work in multiple quadrants, a high speed continuous belt depalletizer, and a fully automatic accumulation system.

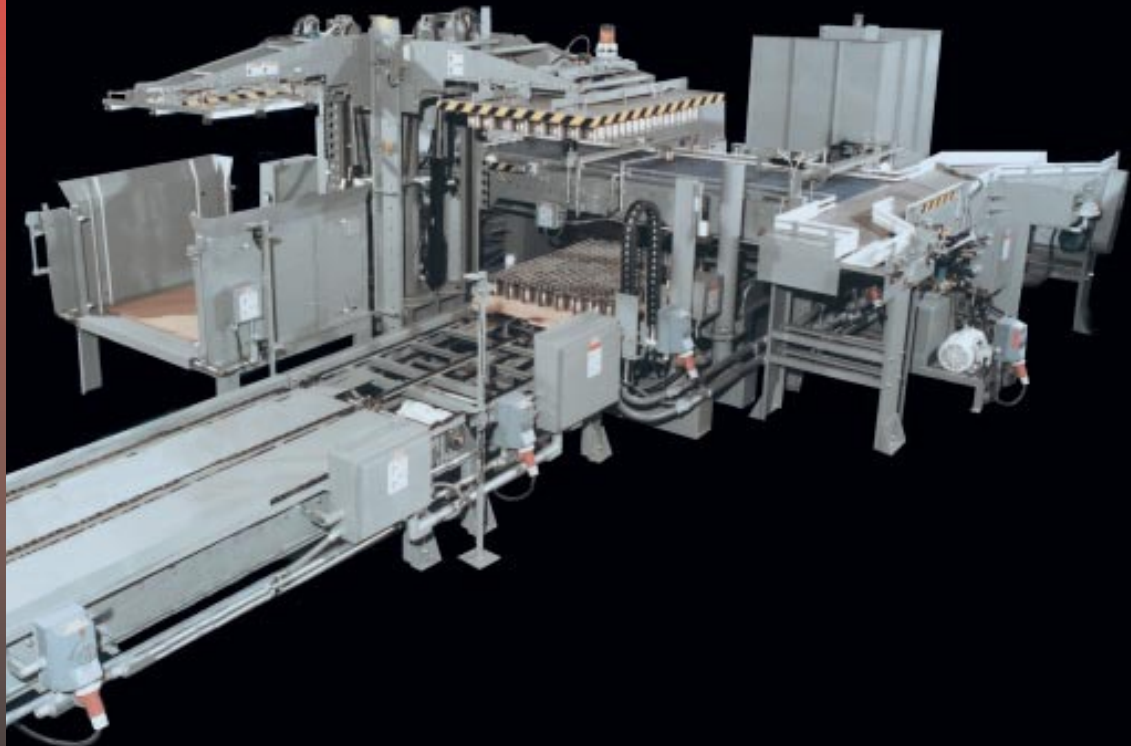

Certain safety features removed for photographic purposes.



MATERIAL HANDLING
EQUIPMENT

WHALLON MACHINERY, INC., P.O. Box 429
205 North Chicago Street, Royal Center, Indiana 46978-0429
574/643-9561 • Fax 574/643-9218
www.whallon.com

Can Palletizer/Depalletizer

SEMI-AUTOMATIC
PALLETIZER/DEPALLETIZER

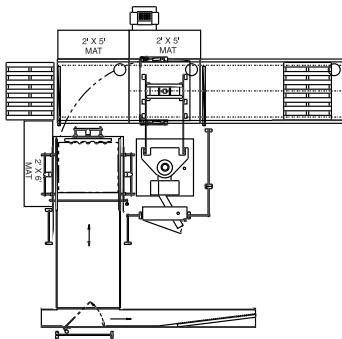

SEMI-AUTOMATIC
PALLETIZER/DEPALLETIZER
WITH FULLY AUTOMATIC PALLET HANDLING

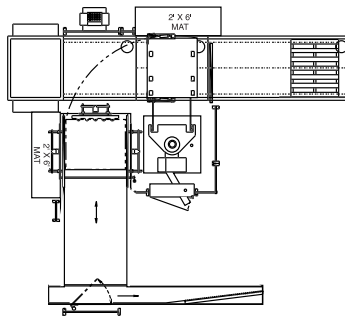

FULLY AUTOMATIC
PALLETIZER/DEPALLETIZER

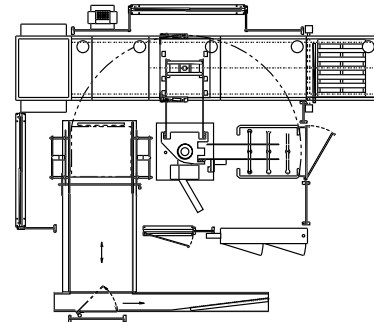

SEMI-AUTOMATIC
PALLETIZER/DEPALLETIZER

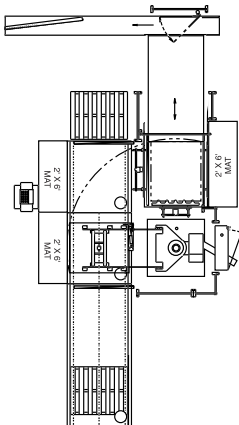

SEMI-AUTOMATIC
PALLETIZER/DEPALLETIZER
WITH FULLY AUTOMATIC PALLET HANDLING

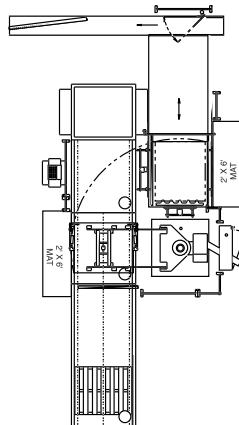

FULLY AUTOMATIC
PALLETIZER/DEPALLETIZER

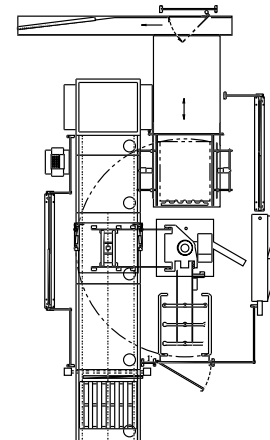

The unit is manufactured with only the highest quality components and proven, reliable controls. A machine can be purchased with standard parts, or the system can be tailor-built with specified motors, valve assemblies, sensors, and programmable logic controllers. The design of the unit allows for easy changeovers, low maintenance and long system life which equals a high quality, reliable investment at an affordable price. Our efforts to provide an affordable unit to the customer do not stop with delivery. Whallon's dedicated and experienced service staff provides assistance with installation, startup, and phone support for all existing equipment.

Whallon's can palletizer/depalletizer has been developed over more than a quarter century of service to the food industry. The advancements in the design, and the electrical, hydraulic, and pneumatic controls demonstrate Whallon's commitment and willingness to provide only the highest quality product to the customer.

All illustrations, descriptions and specifications are based on the latest product information available at the time of publication. Whallon Machinery, Inc. reserves the right to make changes at any time without notice.